

SIMGASM

Hobby Simulator

Assembly Guide

Chassis / Pedal Deck / Wheel Mount

CONTENTS

If you encounter any issues during the assembly, please reach out to us for a resolution in a timely manner.

01

SYMBOL LEGEND

Pg. 02

02

BUILD NOTES

Pg. 03

03

PART LIST/ PACKING SLIP

Pg. 04

04

ASSEMBLY INSTRUCTIONS

Pg. 05-14

VISUAL SYSTEM

- Gold dots mark the exact fastener or slot to use.
- Leader arrows show important details.
- Short callout chips placed inside the visuals details where required.

SYMBOL LEGEND

IMPORTANT

- Open the hardware bags one at a time on a flat surface when needed.
- Leave adjustable hardware loose until the final seating position is confirmed.
- Check the packing slip and step pages before starting the assembly. After reading please start at step one and make sure no steps are skipped.



KEEP LOOSE



CHECK ORIENTATION



SLOTS INWARD



FLAT SIDE OUT



ADJUST HEIGHT



PRESS FIT

REMINDER

- If you encounter any issue during the assembly, please reach out to us for a timely resolution.

BUILD NOTES

Key references to follow before you tighten anything down.

OVERVIEW

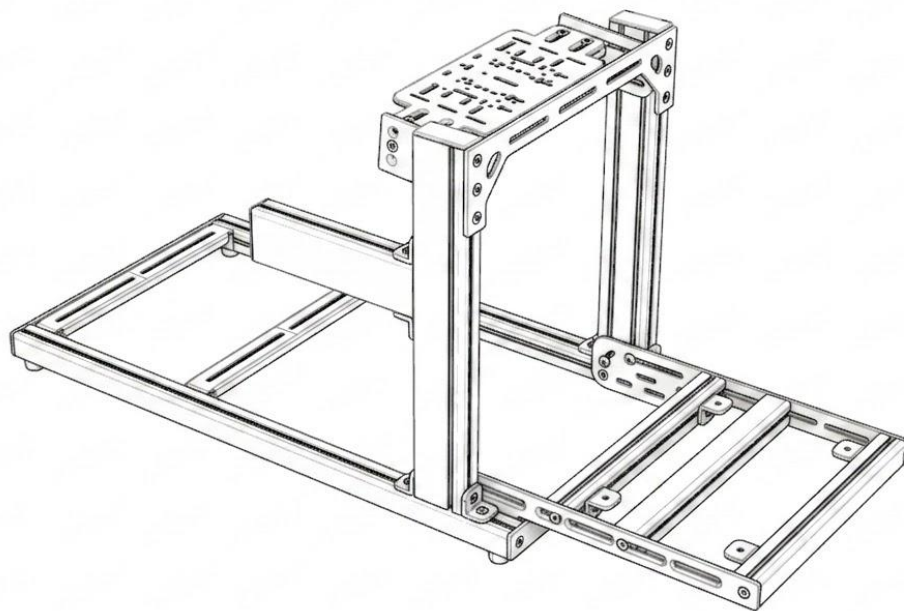

BEFORE YOU START

- Work from the base up and keep adjustable hardware hand-tight until the final alignment pass.
- Pre-check pedal spacing before the pedal deck is fixed to the chassis.
- Wheel-mount height and angle are set last.
- You can press a T-nut sideways into a profile or slot it from an open end.

DETAIL - Inserting T-nuts through the slot

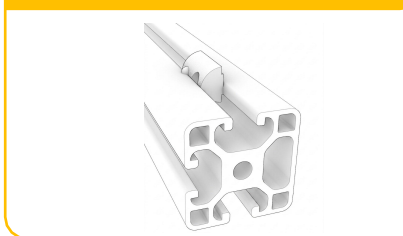

DETAIL - Twist after insert to lock

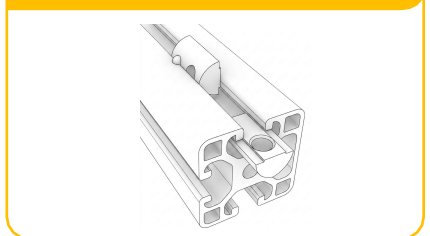

BUILD ON A FLAT SURFACE



DO NOT FORCE HARDWARE



TIGHTEN AT END



CHECK ORIENTATION

REMINDER

- If you encounter any issue during the assembly, please reach out to us for a timely resolution.

PART LIST / PACKING SLIP

Check the kit before assembly so the hardware stays grouped by build step.

ASSEMBLY

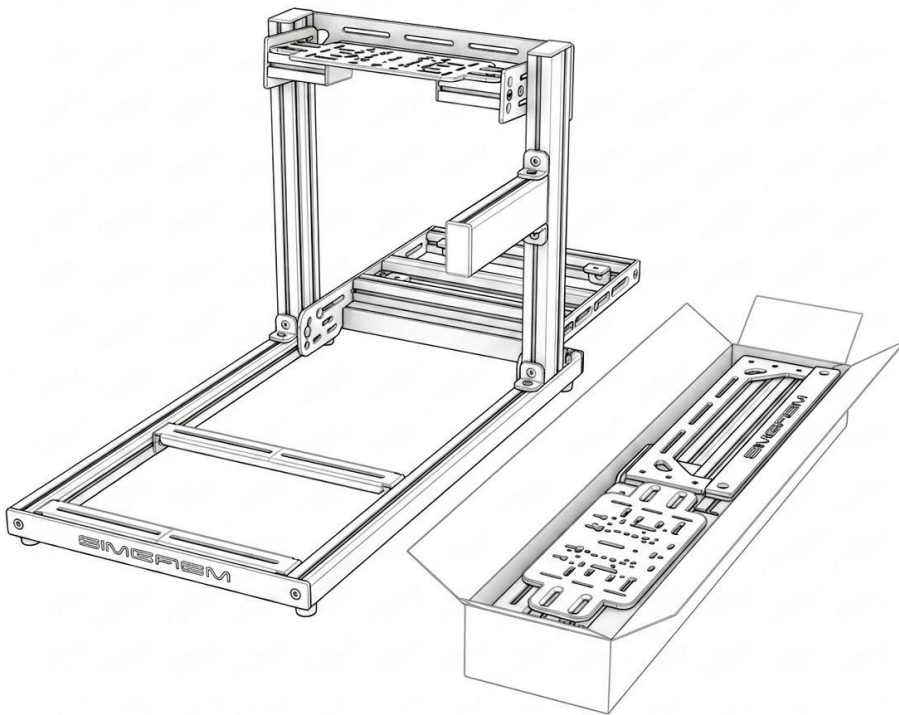

COMPONENTS

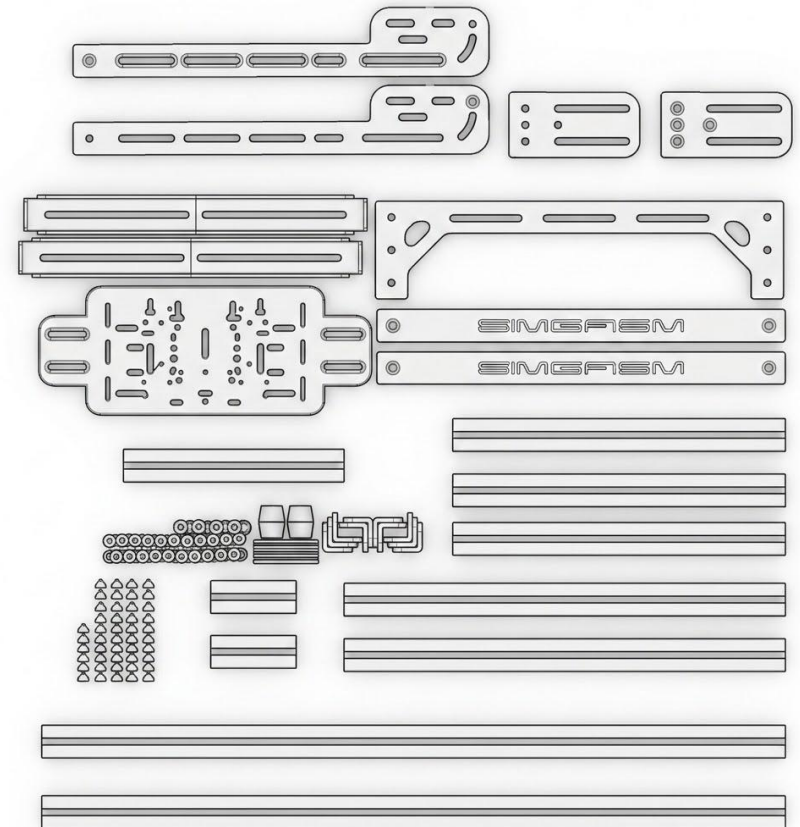

REMINDER

Lay out the profiles, plates and hardware by step. This reduces the chance of missing a part later in the build.

01

INSTALL THE RUBBER FEET

Start with the 92 cm base profiles and leave the hardware hand-tight.

ASSEMBLY

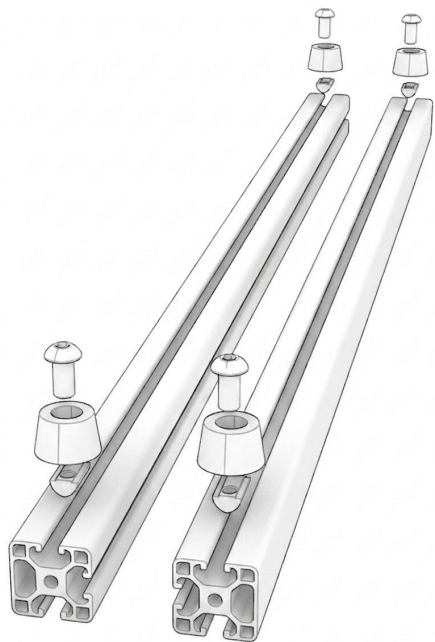

RESULT

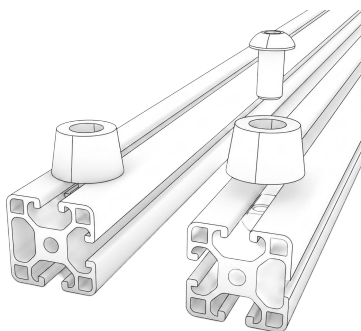

PARTS - Parts for this step



DETAIL - Push through the slot

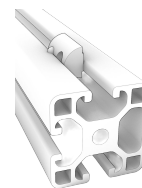

DETAIL - Twist to lock

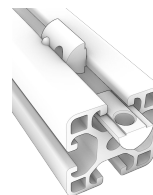

KEEP LOOSE



FLAT SIDE OUT



CHECK ORIENTATION

ASSEMBLY

- Insert one M6 T-nut for each foot near the profile ends.
- Fit the rubber feet with the wide flat face against the profile.
- If the profile end is closed, push the T-nut through the slot sideways and twist it into position.

PARTS REQUIRED

- 2x 92 cm profile
- Single plastic bag contents:
- 4x rubber feet
 - 4x M6 button head bolt
 - 4x M6 T-nut

REMINDER

Keep the feet slightly inboard to avoid overhang after the end plates are fitted.

02

FIT THE END PLATES

Close the base frame and confirm the profile faces before tightening.

ASSEMBLY



PARTS - Parts for this step



DETAIL - Profile orientation detail



RESULT

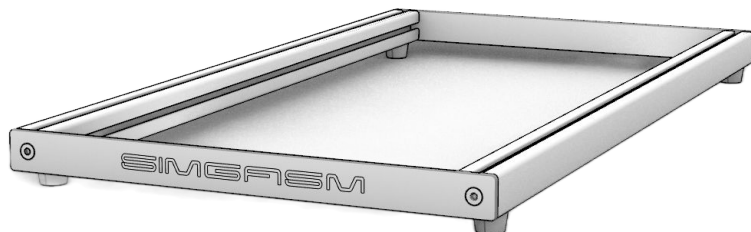

ASSEMBLY

- Screw each countersunk bolt through the metal plate but do not fully tighten it yet. Once both bolts are in fully tighten the bracket with both bolts.
- Keep the logo side of each profile facing outwards.
- The feet should sit on the flat surface when the base is upright.

PARTS REQUIRED

- 2x end plates
- 4x countersunk bolt

REMINDER

Confirm the SIMGASM logo plate faces the front of the chassis.

When you use power tools, do not overtighten these bolts. On a regular power tool setting 6-8 is sufficient.



FLAT SIDE OUT



CHECK ALIGNMENT

03

INSTALL THE SEAT FRAME PLATES

Fit the cross brackets into the side slots and keep them adjustable.

ASSEMBLY



RESULT



PARTS - Parts for this step

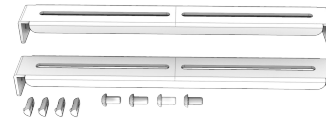

DETAIL - Position the cross brackets

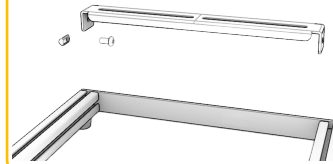

DETAIL- Button head bolt fit

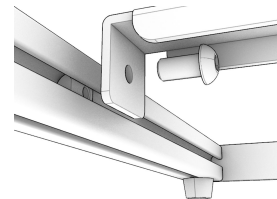

ASSEMBLY

- Add 2x T-nuts per side to the chassis side slots.
- Keep both cross brackets loose until the final seat position and bolt pattern of your seat is known.
- If you have a seat slider check the distance required to mount these on the cross brackets.

PARTS REQUIRED

- 2x cross bracket
- 4x T-nut
- 4x m8x16 button head bolt

REMINDER

Use the slotted side of each bracket for later seat-position adjustment.



KEEP LOOSE



CHECK ALIGNMENT

04 INSTALL THE UPRIGHTS

Bolt the 54 cm profiles to the base frame with the slots facing inward.

ASSEMBLY

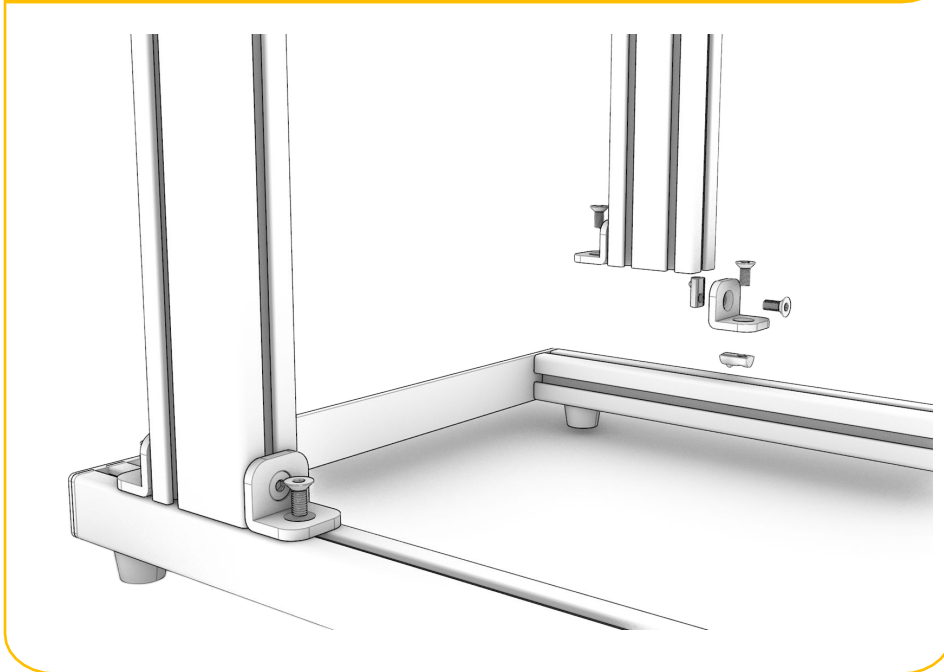

PARTS - Parts for this step

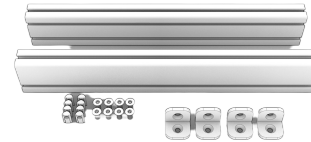

DETAIL - Bracket and T-nut position

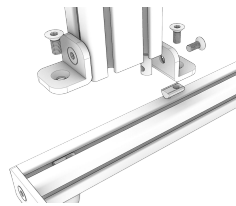

ASSEMBLY

- Have the 2 slots of each upright profile facing inward, toward the centre of the base frame and the outside slot facing the shortest end (front side) of the chassis.
- Set both uprights square before tightening the corner brackets.

PARTS REQUIRED

- 2x 54 cm profile (upright)
- 4x corner bracket
- 8x countersunk bolt
- 8x T-nut

REMINDER

Leave the uprights adjustable until the brace plate and wheel mount are installed.



SLOTS INWARD



KEEP LOOSE



CHECK ALIGNMENT

05

ATTACH THE SHIFTER ARM

Mount the 27 cm shifter arm to the preferred side of the chassis.

ASSEMBLY

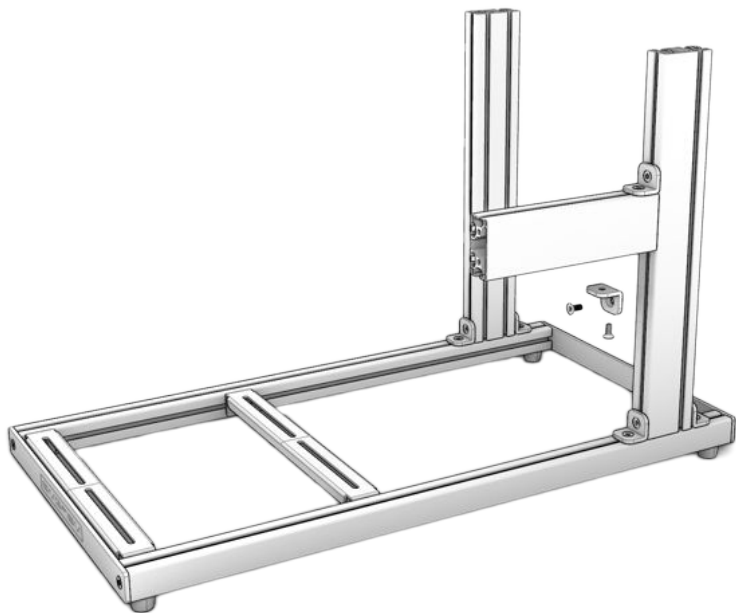

RESULT

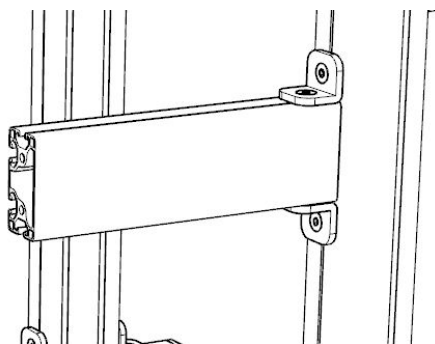

PARTS - Parts for this step



DETAIL - Shifter arm bracket stack

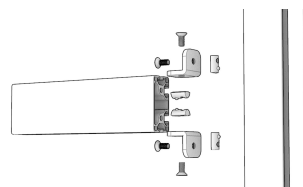

ASSEMBLY

- Mount the shifter arm on the left or right side of the base.
- Keep the 2-slot face inward unless you need accessories on the outside.
- Depending on your needs the profile can be mounted in any orientation

PARTS REQUIRED

- 1x 27 cm profile (shifter arm)
- 2x corner bracket
- 4x countersunk bolt
- 4x T-nut

REMINDER

Match the shifter arm height to the later seat and wheel position.



OPTIONAL SIDE



CHECK ORIENTATION

06

ASSEMBLE THE PEDAL DECK

Build the pedal tray and set the profile spacing to suit your pedals.

ASSEMBLY

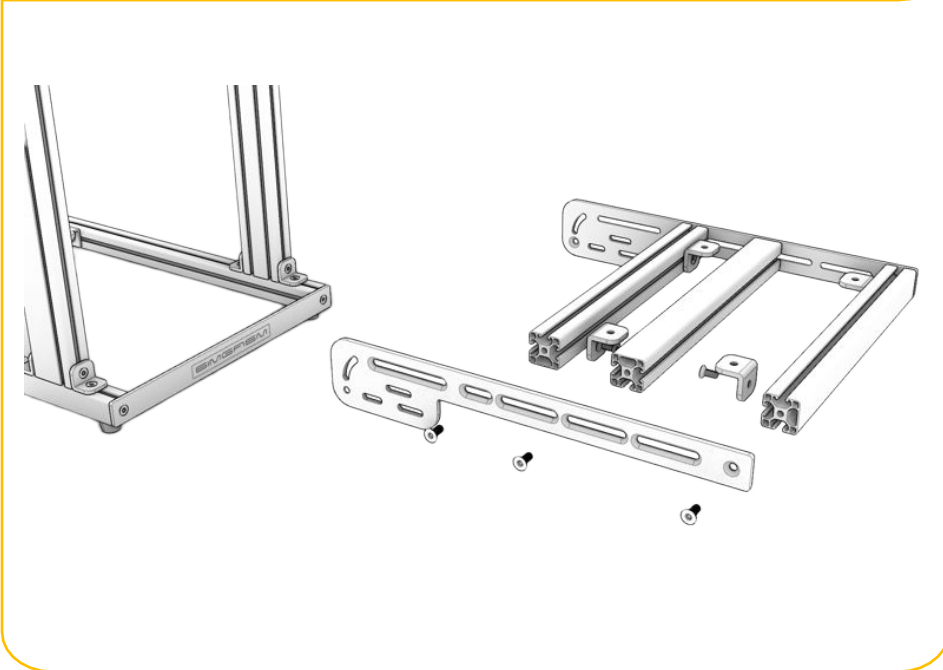

RESULT

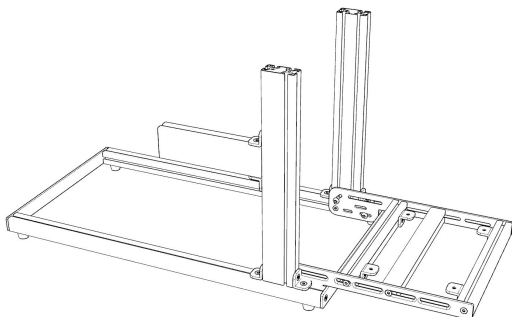

PARTS - Parts for this step

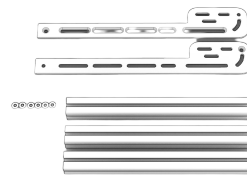

DETAIL - Attaching peripherals from both sides

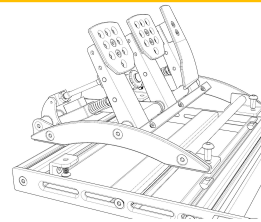

DETAIL - Attaching peripherals from bottom

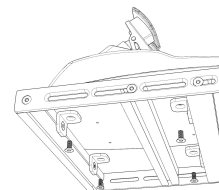

CHECK ORIENTATION



KEEP LOOSE

ASSEMBLY

- Set the 3 profile positions to suit your pedal set before final tightening the side brackets.
- Where possible, keep the closed side of the profiles facing up to avoid dust accumulation over time
- T-nuts can be used in the profiles to bolt directly through pedal sets or the corner brackets can be used to mount pedals from the bottom.

PARTS REQUIRED

- 2x pedal bracket
 - 3x 40.7 cm profile
 - 6x countersunk bolt
- Optional for bottom mounting:
- 4x corner bracket
 - 4x T-nut
 - 4x countersunk bolt

REMINDER

Leave enough slot travel for the final pedal spacing adjustment.

07

MOUNT THE PEDAL DECK

Fix the pedal tray to the chassis and adjust the height and angle.

ASSEMBLY

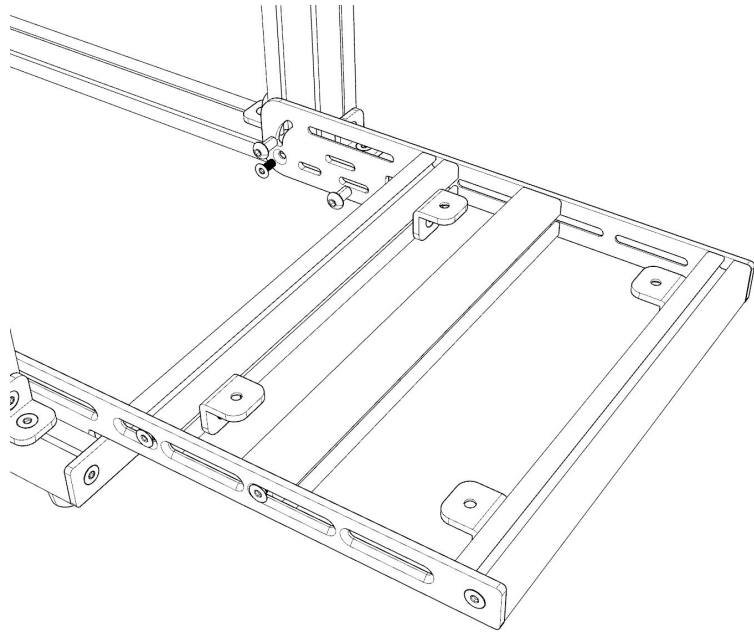

RESULT

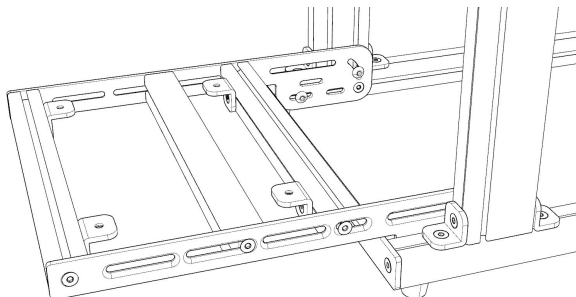

PARTS- Parts for this step

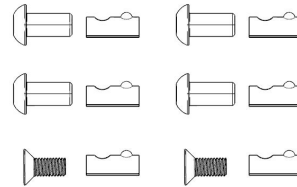

DETAIL - Bolt position

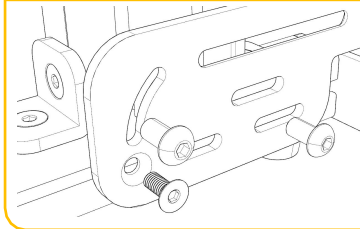

ASSEMBLY

- Use the upright and base slots to set deck height and angle before tightening.
- For best stiffness, use at least 3 bolts per side into the base frame/upright or when the pedal plate is resting on the front plate.

PARTS REQUIRED

- 2x countersunk bolt
- 4x T-nut
- 4x m8x16 button head bolt

REMINDER

Confirm the deck sits square before tightening all side bolts.



CHECK ALIGNMENT



ADJUST HEIGHT / ANGLE



TIGHTEN AT END

08

INSTALL THE BRACE PLATE

Span the uprights and set the wheel support height before final tightening.

ASSEMBLY

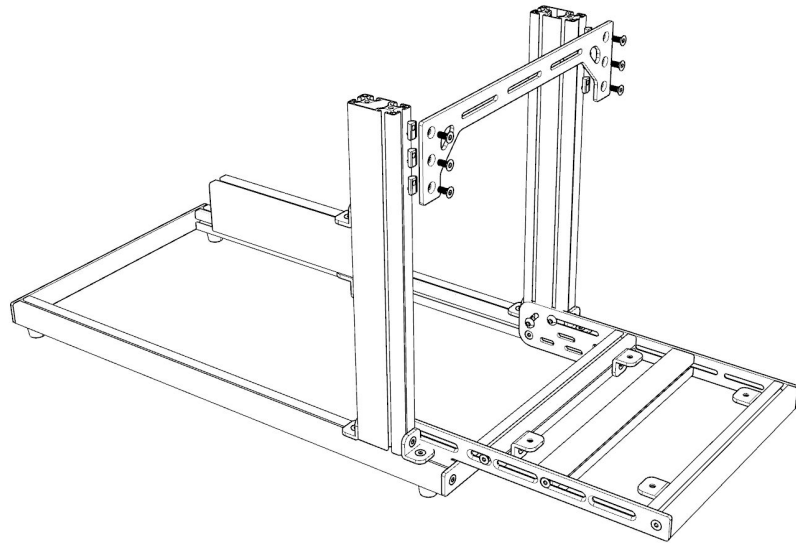

RESULT

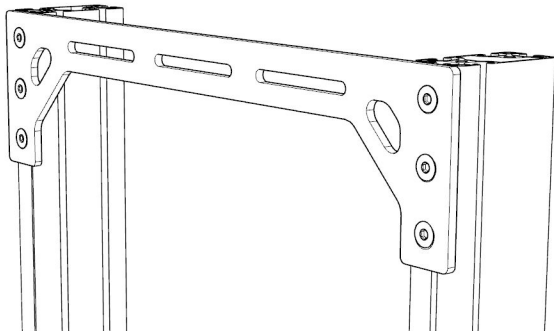

PARTS - Parts for this step



ASSEMBLY

- Set the brace plate height to suit your wheel position.
- The brace plate can be inverted if that gives a better wheel-mount layout.
- This brace can be used as a mounting point for your PC Shelf Add-On

PARTS REQUIRED

- 1x brace plate
- 6x T-nut
- 6x countersunk bolt

REMINDER

Check the height again with the wheel mount before you fully tighten the upright bolts.



ADJUST HEIGHT



OPTIONAL ORIENTATION

09

CONFIGURE THE WHEEL MOUNT

Choose the mount option that matches your wheelbase and driving position.

MOUNT OPTIONS

Choose the wheel mount that matches your wheelbase. The labels below correct the earlier front/bottom swap.

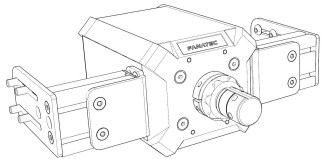

SIDE MOUNT
Bracket on wheel sides

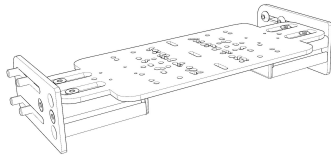

BOTTOM MOUNT
Plate under wheelbase

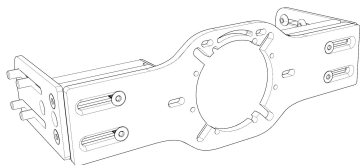

FRONT MOUNT
Plate in front

DETAIL - Assembly side wheel mount plate to chassis

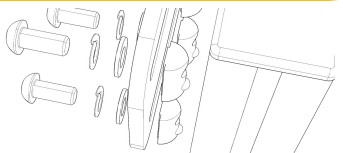

DETAIL - Assembly washers on button head bolt

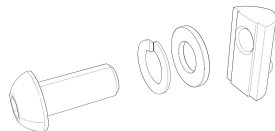

PARTS - Parts for this step

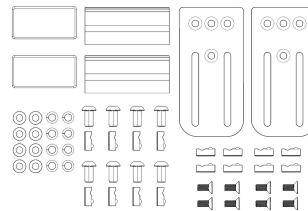

DETAIL - Assembly front and side wheel mount

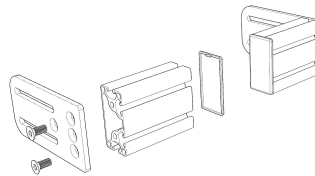

DETAIL - Assembly bottom wheel mount

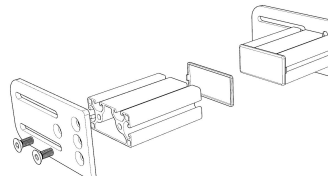

CHOOSE MOUNT OPTION



CHECK ALIGNMENT



TIGHTEN AT END

ASSEMBLY

- Choose the mount style that matches your wheelbase. Side and Front, use the bottom and top holes of the side plate, bottom use the middle holes.
- For the side mount, bolt the side brackets to your motor first to avoid accessibility issues when mounting the motor at a later stage.
- Insert the T-nuts in the uprights and bolt it down with the bolts through the metal plates after attaching the metal plates to the profiles.

PARTS REQUIRED

- 2x 10.5 cm profile
- 12x T-nut
- 2x adjustable bracket
- 8x countersunk bolt
- 8x m8x20 button head bolt
- 2x end cap
- 8x spring washer
- 8x flat washer

REMINDER

After final height and angle are set, retighten all 8 upright bolts.

10

INSTALL THE END CAPS

Finish the chassis and complete the final alignment check.

ASSEMBLY

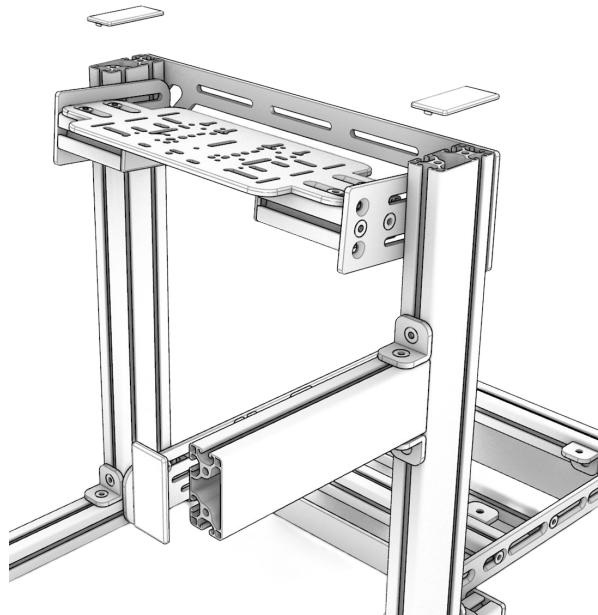

RESULT

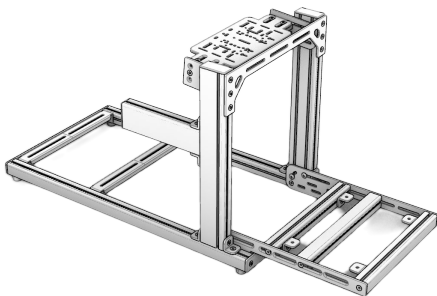

PARTS - Parts for this step

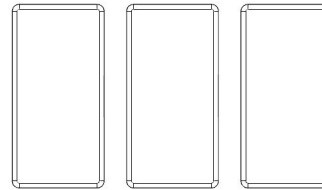

DETAIL - Installation of end cap on upright



ASSEMBLY

- Push each cap by hand until it is fully seated and avoid tapping it with tools to sit flush.
- Complete a final alignment and hardware check before use.
- Your SIMGASM Hobby Simulator chassis is now ready for pedal and wheel base setup.

PARTS REQUIRED

- 3x end cap

REMINDER

Tighten the shifter arm, pedal deck and wheel support once you confirm your final seating position.



PRESS FIT



FINAL CHECK

01 Optional - Seat Sliders

Add the seat slider to the chassis.

ASSEMBLY

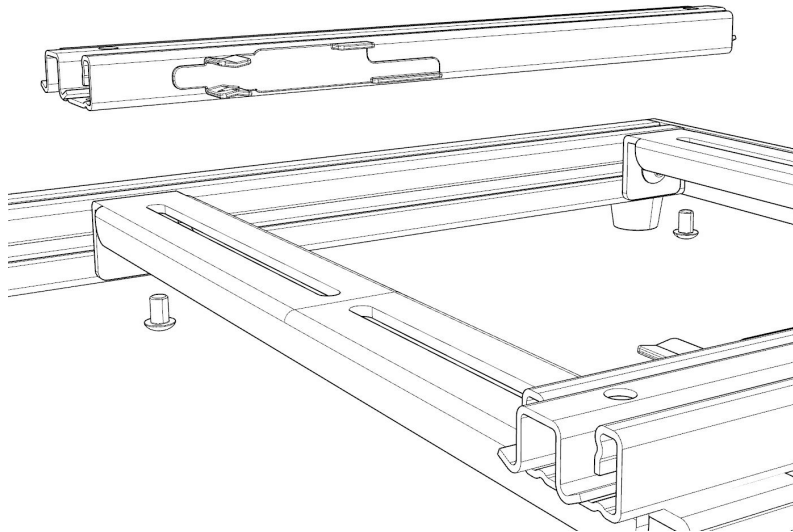

RESULT

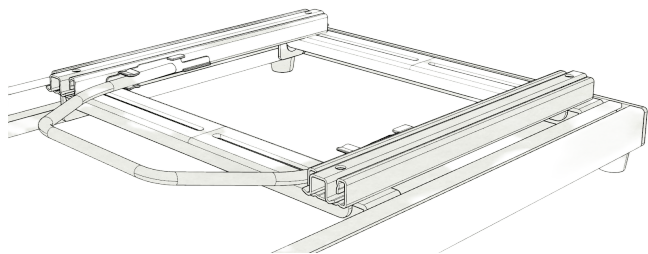

DETAIL

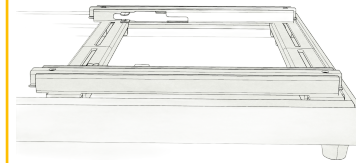

ASSEMBLY

Place each slider on top of the cross brackets and align the nut in front of the slotted brackets.

- Ensure the release mechanism is facing inwards on both sides and the pin is facing the backside of the chassis with the U shaped bracket facing forward.
- Bolt goes from the bottom into the slider directly.

PARTS REQUIRED

- 1x seat slider set
- 1x slider handle
- 4x m8x12 bolt

REMINDER

Fully Tighten the Sliders once both are square and functional for adjusting the seating position.



FLAT SIDE OUT



CHECK ALIGNMENT



TIGHTEN AT END

02

Optional - Seat Brackets

Add the seat brackets to the slider.

ASSEMBLY

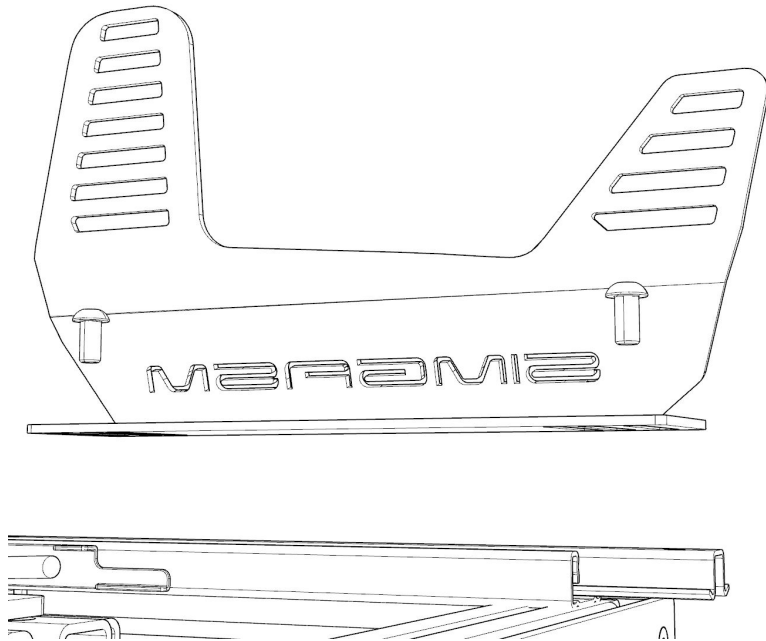

RESULT

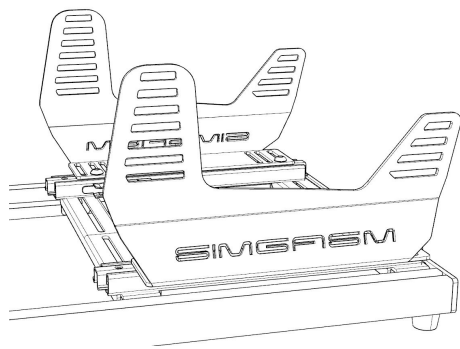

CHECK ALIGNMENT



TIGHTEN AT END

ASSEMBLY

- Place each bracket on top of the slider and align the nut in front of the slotted brackets.
- Bolt goes from the top into the slider directly without the need of an additional nut.
- Alternatively you can move the slider from front to back and insert a regular nut underneath the slot and tighten the bolt from above.

PARTS REQUIRED

- 1x Seat bracket set
- 4x m8x12 bolt
- Optional: 4x m8 nut

REMINDER

Fully Tighten the brackets once both are square and at the right distance for your desired seat.

02

Optional - Core seat

Install the Core seat to the slider

ASSEMBLY

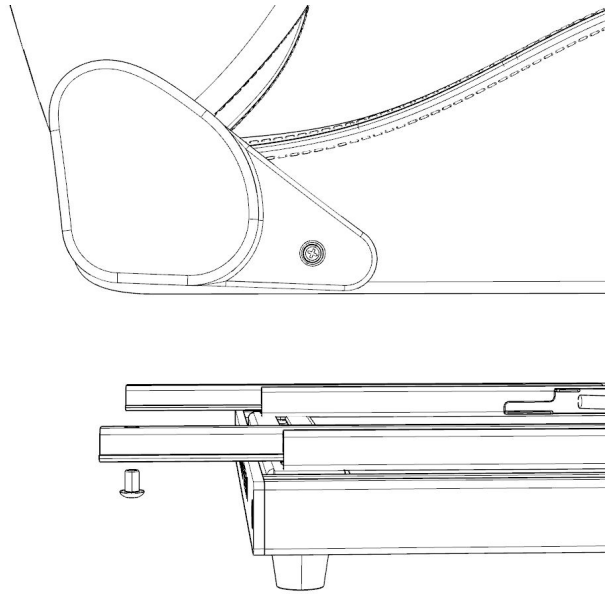

RESULT

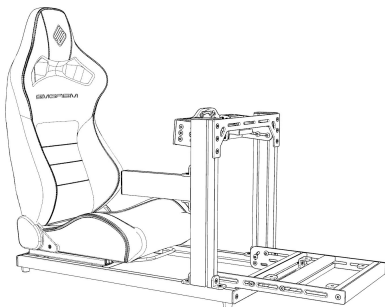

DETAIL

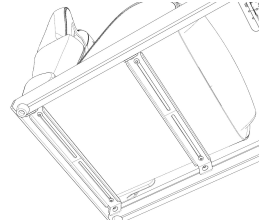

ASSEMBLY

- To bolt bottom mounted Core seats directly onto the slider, slide the seat rails back and insert the bolt from the bottom directly into the seat and tighten it.
- Same for the front side however then slide the seat slider forward.
- If you don't use a slider, the seat bolts directly through the cross bracket.

PARTS REQUIRED

- 1x SIMGASM Core seat
- 4x m8x16 bolt

REMINDER

Fully tighten the brackets once both are square and at the right distance for your desired seat.



CHECK ALIGNMENT



TIGHTEN AT END